

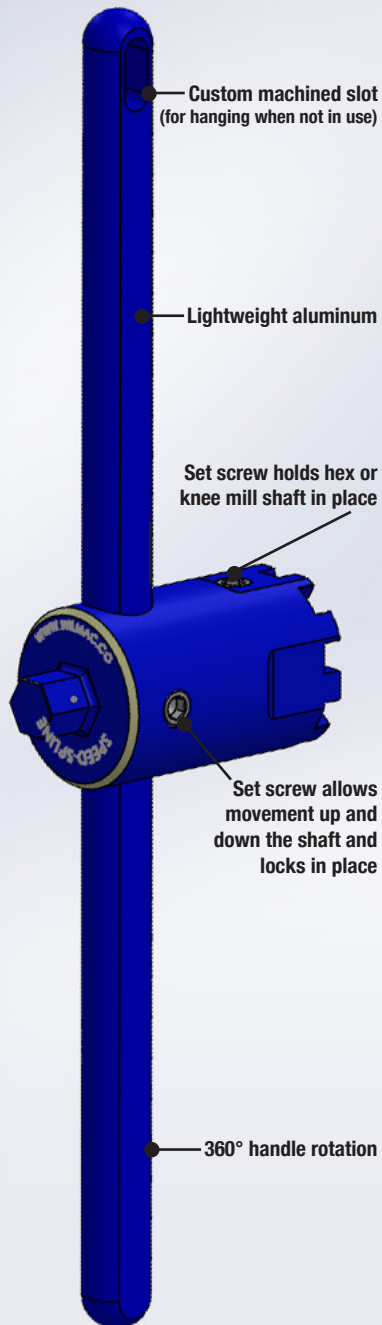

# SPEED SPLINE

Machine Vice Handle  
Patent Pending



## *The Most Versatile, Universal Machine Vice Handle for use with CNC Machining Centers and Milling Machines*

- 360° handle rotation (no need to remove multiple times to fit)
- Handle moves in both directions for max torque on vice's hex shaft (No need to remove handle from vice before machine operations)
- Adjustable low profile design with no interference during machine operations
- Integral set screw allows tool to be moved up and down the shaft and permanently installed and locked in position when needed
- Holds workpiece stationary during cutting operations
- Tightens and loosens vices with ease
- .7 lb robust aluminum design provides light-weight tool
- Hardcoat anodize for wear resistance
- Provided 1/2" nut driver to use with drill for fast action
- Magnetic hook included